

TAS84

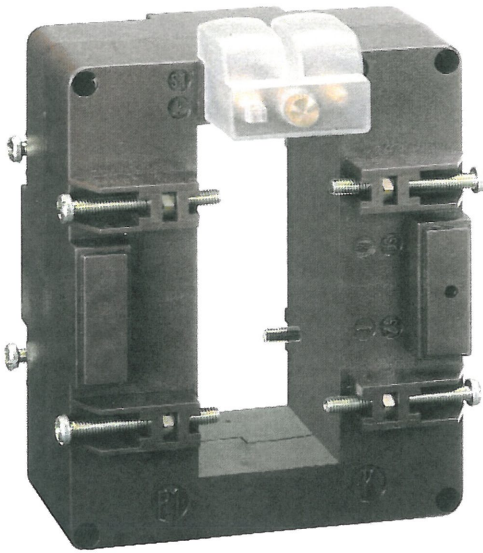

Aufsteckstromwandler für Primärschiene
Primärstrom 150...2500A
Sekundärstrom 1A - 5A

Angewandte Normen
EN60044-1, BS3938, BS7626

Gehäuse
Gehäusematerial:
Polycarbonat selbstverlöschend,
Klassifizierung V0 nach UL-94
Schutzart (EN60529):
IP00 Anschluss (IP20 mit Klemmen-
abdeckung), IP20 Gehäuse
Primärschienenbefestigung
Tropenausführung (Option)
Gewicht: 700 Gramm

Anschluss
Sekundäranschluss:
Gewindebolzen M4

**Passing bus bar primary
Single-phase current transformer**
Primary current 150...2500A
Secondary current 1A - 5A

Reference standards
EN60044-1, BS3938, BS7626

Housing
Housing material:
self extinguishing polycarbonate,
classification V0 according to UL-94
Protection degree (EN60529):
IP00 terminals (IP20 with terminal with
shroud), IP20 housing
Fixing screw facilities for bar
Tropicalized version
Weight: 700 grams

Connections
Secondary winding:
tightening by nut M4

Nennstrom primär Rated primary current	Bürde Rated burdens				
	KI.0,5	KI.1	KI.3	sekundär 5A Secondary 5A	sekundär 1A Secondary 1A
	VA	VA	VA	Bestellnummer Order code	Bestellnummer Order code
A					
150			2	TASO50C150	TASO10C150
160			2	TASO50C160	TASO10C160
200			4	TASO50C200	TASO10C200
250			5	TASO50C250	TASO10C250
300		2	6	TASO50C300	TASO10C300
400	3	5	8	TASO50C400	TASO10C400
500	5	7	10	TASO50C500	TASO10C500
600	6	10	12	TASO50C600	TASO10C600
750	8	12	15	TASO50C750	TASO10C750
800	8	12	15	TASO50C800	TASO10C800
1000	10	15	20	TASO50D100	TASO10D100
1200	12	15	20	TASO50D120	TASO10D120
1250	12	15	20	TASO50D125	TASO10D125
1500	15	20	25	TASO50D150	TASO10D150
1600	15	20	25	TASO50D160	TASO10D160
2000	20	25	30	TASO50D200	TASO10D200
2500	25	30	40	TASO50D250	TASO10D250

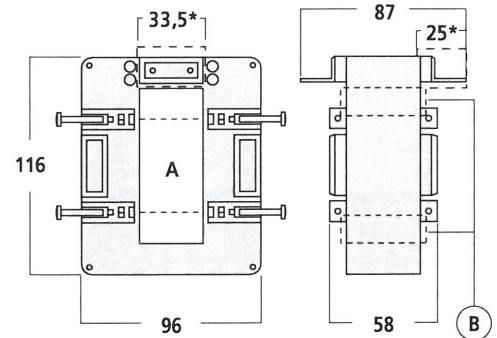

B: Option
Option

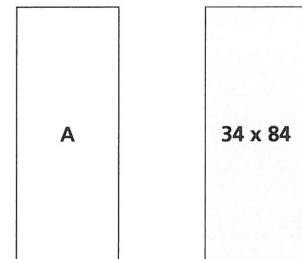

B: Anpassung für Schiene 60mm (Option)
Spacing device for bars of 60mm

Sonderausführung Possible option	Bestellnummer (Zusatz) Option code
Tropenausführung - erschütterungsfest tropicalized - vibrationproof	2
Sekundäranschluss an langer Seite terminals on long side	3
Tropenausführung - erschütterungsfest - Sekundäranschluss an langer Seite tropicalized - vibrationproof - terminals on long side	A
P.S.: der Bestellnummerzusatz muss am Ende der Bestellnummer hinzugefügt werden N.B. : option code must be written at the end of order code	

Zubehör On request	Bestellnummer Order code
Anpassung für Schiene 60mm adapter for bar 60mm	ATADIS01